

• Controller Electric Circuit For Programmable Controller (STC-P316U)

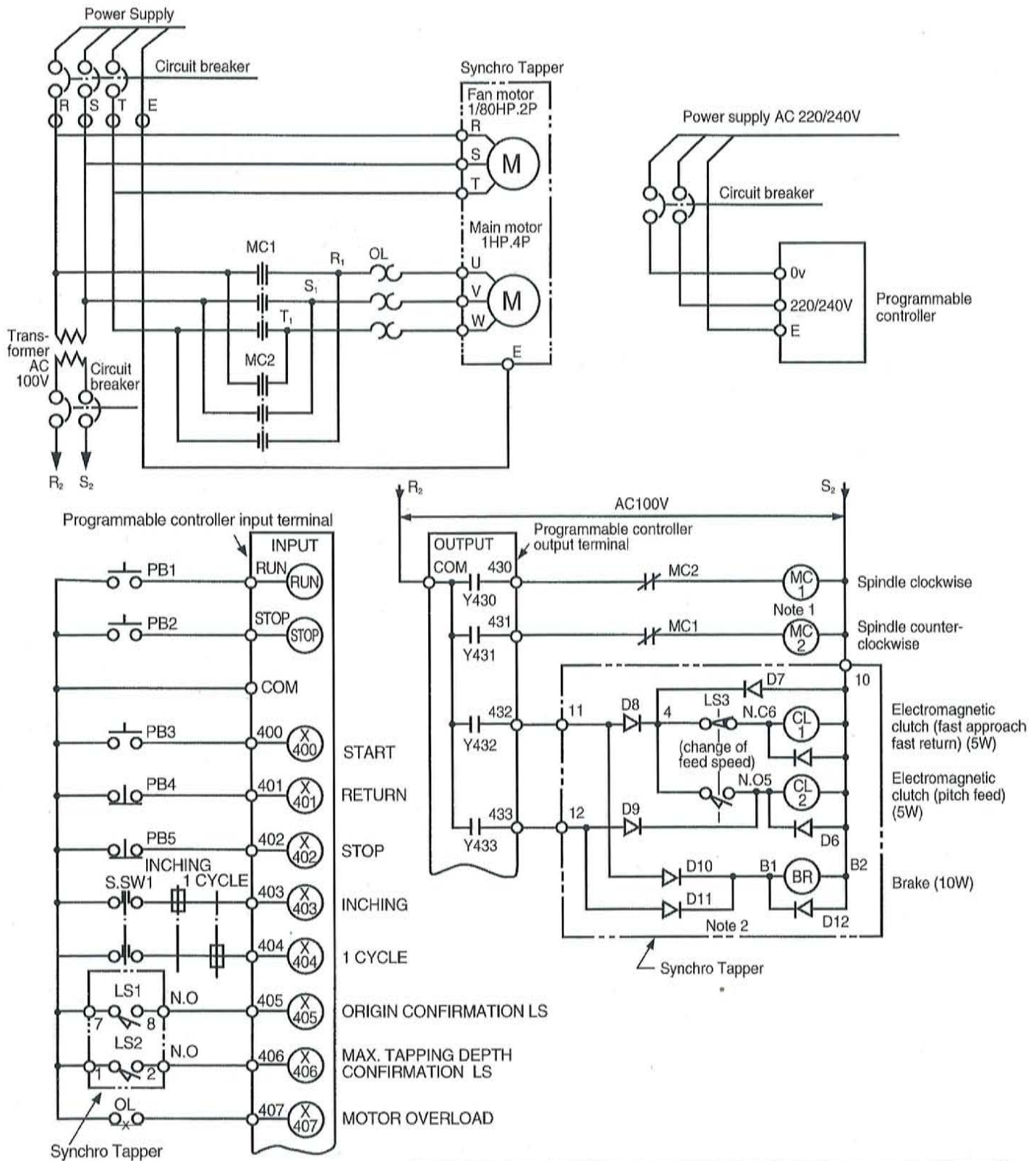

Notes:

1. Spindle rotation (clockwise and counter-clockwise) should be controlled by magnetic contactor (MC1, MC2) with mechanical interlock (supplied by customer).
2. AC100V source voltage is converted within the unit to DC45V for electro-magnetic clutches

Control Program (STCP316U)

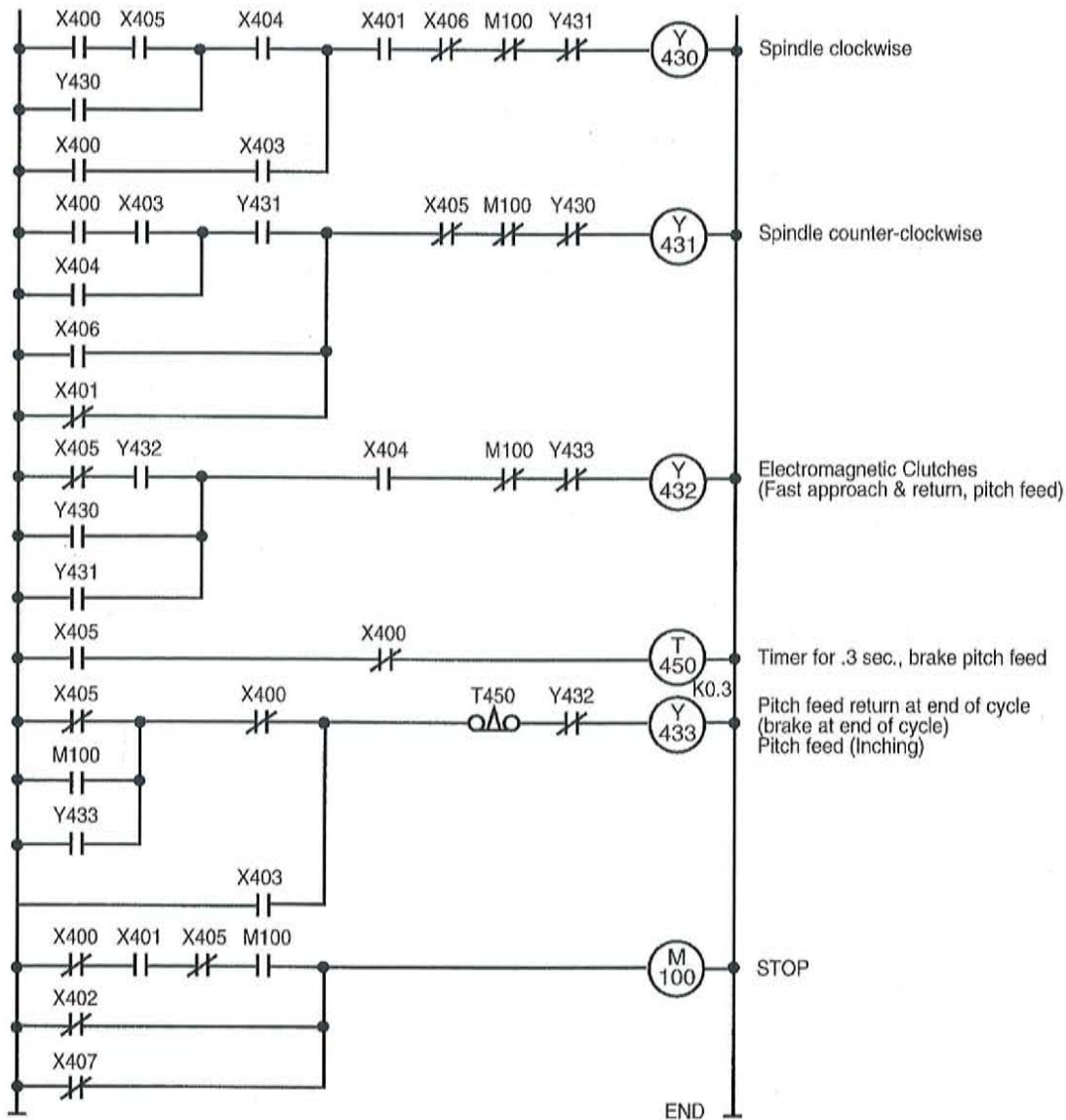

Operation Chart for One Cycle

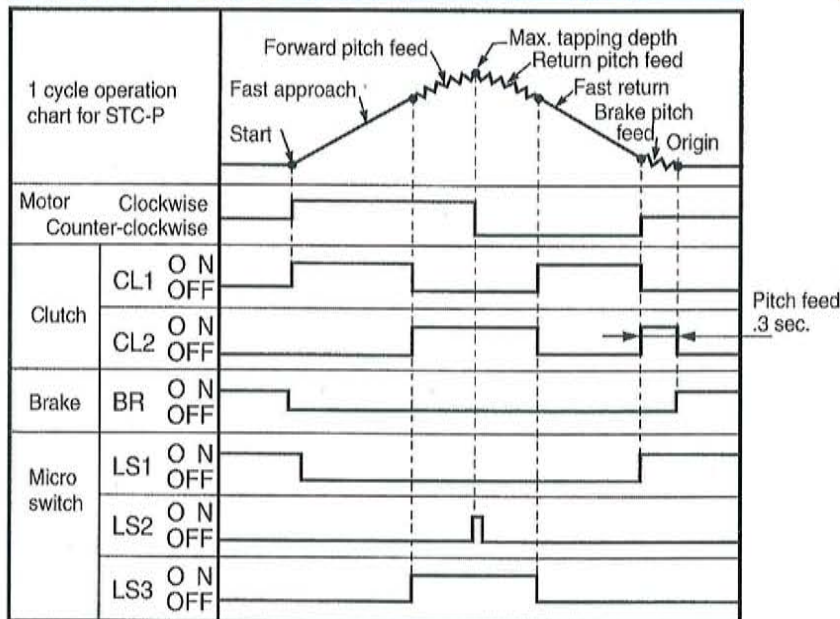

Travel Chart for One Cycle

