

Controller Electric Circuit For Programmable Controller (STE-522)

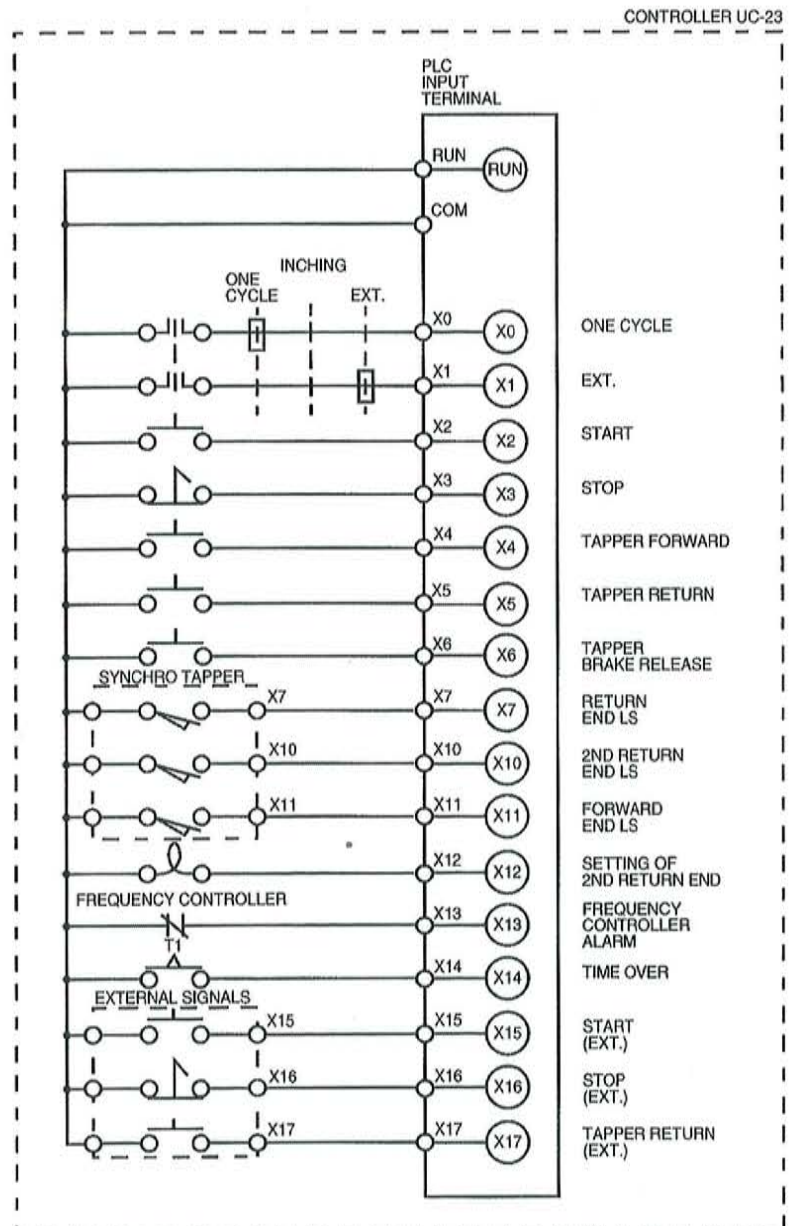
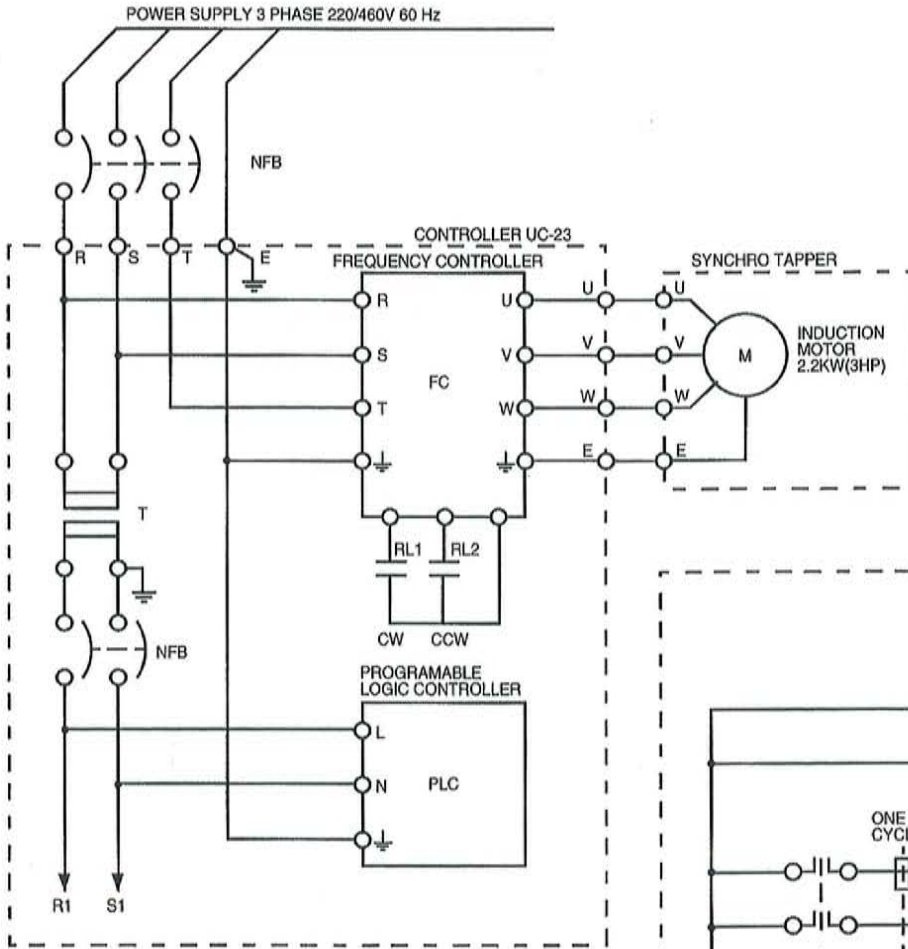

Notes:

- Control voltage R2-S2 of PLC output circuit will be provided in accordance with user's circuit.
- Contact capacity for Synchro Tappers internal limit switches:
 MAX. 0.1A@ AC 125V
 MAX. 0.1A@ DC 30V

Programmable Controller (STE-522)

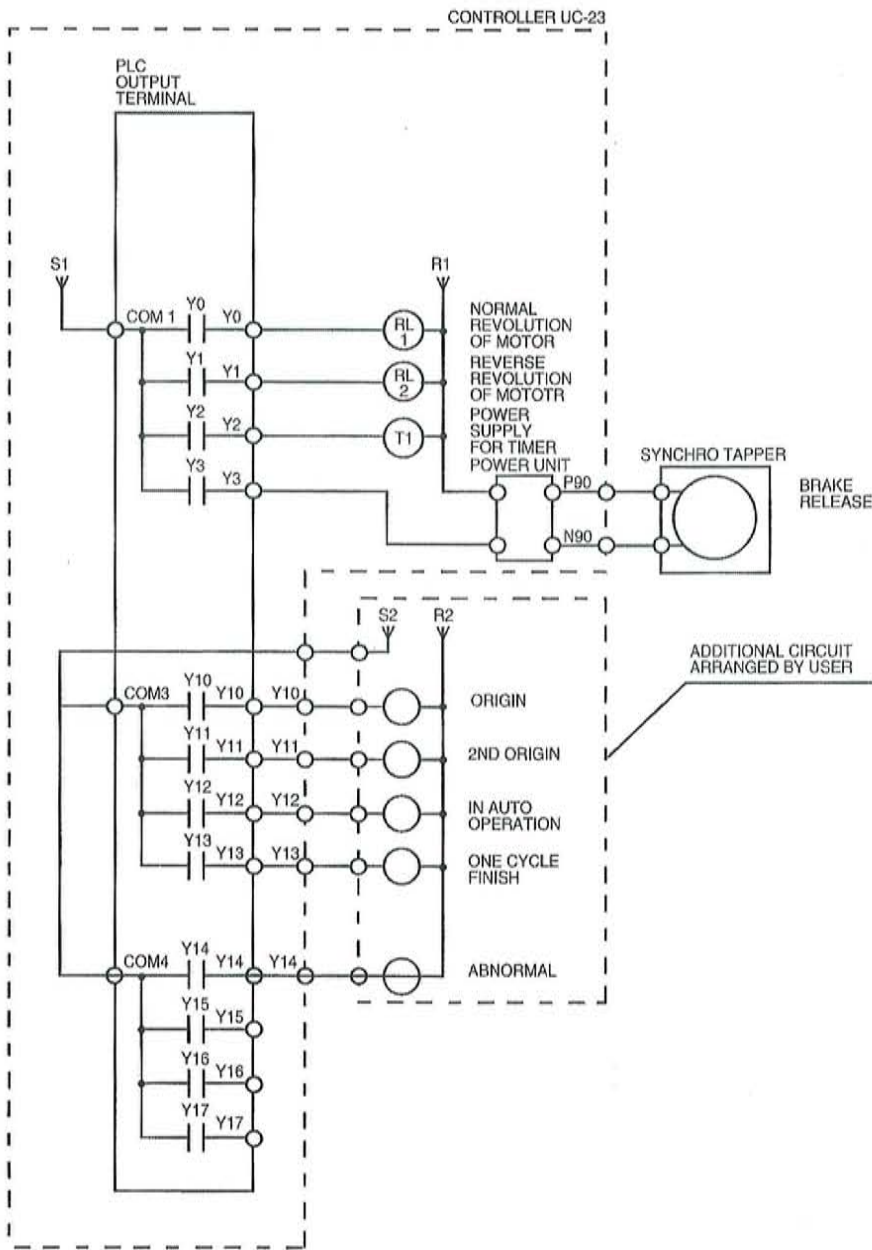

Operation Chart for One Cycle

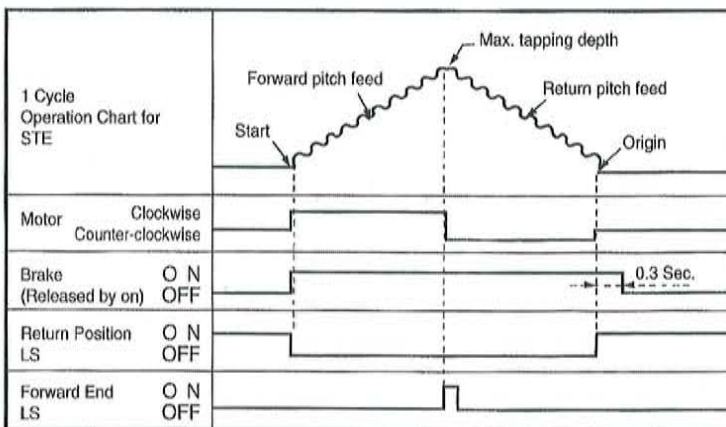

Travel Chart for One Cycle

